

產品標示法：PFB-dxL(PFB-內徑 X 長度)

內徑 Ød	外徑 ØD	軸徑 shaft	孔座H7 housing	L 0 -0.3													
				4	5	6	8	10	12	15	20	25	30	40	50		
4	6	4 -0.013 -0.028	6 +0.015 0	0404	0405	0406	0408										
5	7	5 -0.013 -0.028	7 +0.015 0	0504	0505	0506	0508										
6	8	7 -0.013 -0.028	8 +0.015 0	0604	0605	0606	0608	0610	0612								
8	10	8 -0.013 -0.028	1 +0.015 0		0805	0806	0808	0810	0812	0815							
10	12	10 -0.016 -0.034	12 +0.018 0			1006	1008	1010	1012	1015	1020						
12	14	12 -0.016 -0.034	14 +0.018 0			1206	1208	1210	1212	1215	1220	1225					
13	15	13 -0.016 -0.034	15 +0.018 0				1308	1310	1312	1315	1320						
14	16	14 -0.016 -0.034	16 +0.018 0					1410	1412	1415	1420	1425					
15	17	15 -0.016 -0.034	17 +0.018 0				1508	1510	1512	1515	1520	1525					
16	18	16 -0.016 -0.034	18 +0.018 0					1610	1612	1615	1620	1625					
17	19	17 -0.016 -0.034	19 +0.018 0					1710	1712	1715	1720						
18	20	18 -0.020 -0.041	20 +0.021 0					1810	1812	1815	1820	1825					
20	23	20 -0.020 -0.041	23 +0.021 0					2010	2012	2015	2020	2025	2030				
22	25	22 -0.020 -0.041	25 +0.021 0					2210	2212	2215	2220	2225	2230				
24	27	24 -0.020 -0.041	27 +0.021 0							2415	2420	2425	2430				
25	28	25 -0.020 -0.041	28 +0.021 0					2510	2512	2515	2520	2525	2530	2540	2550		
28	32	28 -0.020 -0.041	32 +0.025 0						2812	2815	2820	2825	2830	2840			
30	34	30 -0.025 -0.050	34 +0.025 0						3012	3015	3020	3025	3030	3040	3050		
32	36	32 -0.025 -0.050	36 +0.025 0								3220	3225	3230	3240			
35	39	35 -0.025 -0.050	39 +0.025 0						3512	3515	3520	3525	3530	3540	3550		
38	42	38 -0.025 -0.050	42 +0.025 0							3815	3820	3825	3830	3840			
40	44	40 -0.025 -0.050	44 +0.025 0						4012	4015	4020	4025	4030	4040	4050		

內徑 Ød	外徑 ØD	軸徑 shaft	孔座H7 housing	L 0 -0.3											
				20	25	30	40	50	60	70	80	90	100	120	
45	50	45 -0.025 -0.050	50 +0.025 0	4520	4525	4530	4540	4550							
50	55	50 -0.030 -0.060	55 +0.030 0	5020	5025	5030	5040	5050	5060						
55	60	55 -0.030 -0.060	60 +0.030 0		5525	5530	5540	5550	5560						
60	65	60 -0.030 -0.060	65 +0.030 0			6030	6040	6050	6060	6070	6080				
65	70	65 +0.036 +0.005	70 +0.030 0			6530	6540	6550	6560	6570					
70	75	70 +0.036 +0.005	75 +0.030 0			7030	7040	7050	7060	7070	7080				
75	80	75 +0.036 +0.005	80 +0.030 0			7530	7540	7550	7560	7570	7580				
80	85	80 +0.036 +0.005	85 +0.035 0				8040	8050	8060	8070	8080		80100		
85	90	85 +0.035 0	90 +0.035 0				8540	8550	8560		8580		85100		
90	95	90 +0.035 0	95 +0.035 0				9040	9050	9060		9080	9090	90100		
95	100	95 +0.035 0	100 +0.035 0					9550	9560		9580		95100		
100	105	100 +0.035 0	105 +0.035 0					10050	10060	10070	10080		100100	100120	
105	110	105 +0.035 0	110 +0.035 0					10550	10560	10570	10580			105120	
110	115	110 +0.035 0	115 +0.035 0					11050	11060	11070	11080		110100	110120	
120	125	120 +0.035 0	125 +0.035 0					12050	12060	12070	12080		120100		
125	130	125+0.035 -0.005	130 +0.040 0						12560				125100	125120	
130	135	130 +0.035 -0.005	135 +0.040 0					13050	13060		13080		130100		
140	145	140 +0.035 -0.005	145 +0.040 0					14050	14060		14080		140100		
150	155	150 +0.035 -0.005	155 +0.040 0					15050	15060		15080		150100		
160	165	160 +0.035 -0.005	165 +0.040 0					16050	16060		16080		160100	160120	
180	185	180 0 -0.046	185 +0.046 0								18080		180100		
190	195	190 0 -0.046	195 +0.046 0								19080		190100		
200	205	200 0 -0.046	205 +0.046 0							20060	20080		200100		
220	225	220 0 -0.046	225 +0.052 0								22080		220100		
250	255	250 0 -0.052	255 +0.052 0								25080		250100		
260	265	260 0 -0.052	265 +0.052 0								26080		260100		
280	285	280 0 -0.052	285 +0.052 0								28080		280100		
300	305	300 0 -0.052	305 +0.052 0								30080		300100		

PFF FLANGED BUSH SERIES

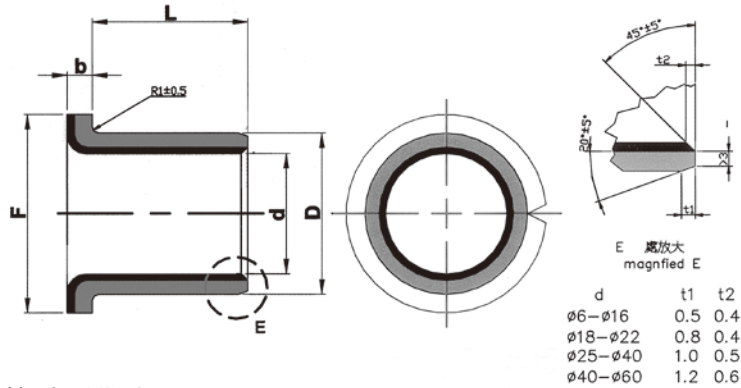

產品標示法：PFF-dxL(PFF-內徑 X 不含凸緣的長度)

內徑 Ød	外徑 ØD	凸緣外徑 ØF±0.5	凸緣厚度 b-0.2	L±0.25													
				4	5	6	7	8	10	12	15	20	25	30	40		
5	7	10	1	0504	0505	0506											
6	8	12	1		0605	0606	0607	0608									
7	9	13	1		0705		0707										
8	10	15	1			0806		0808	0810	0812							
10	12	18	1			1006	1007	1008	1010	1012	1015						
12	14	20	1			1206	1207	1208	1210	1212	1215						
14	16	22	1						1410	1412	1415						
15	17	23	1						1510	1512	1515	1520					
16	18	24	1						1610		1615	1620					
18	20	26	1						1810	1812	1815	1820					
20	23	30	1.5						2010	2012	2015	2020	2025				
22	25	32	1.5						2210	2212	2215	2220					
25	28	35	1.5						2510	2512	2515	2520	2525				
30	34	42	2							3012	3015	3020	3025	3030			
35	39	47	2							3512		3520	3525	3530	3540		
40	44	53	2							4012		4020	4025	4030	4040		
45	50	60	2.5									4520	4525	4530	4540		
50	55	65	2.5									5020		5030	5040		
55	60	70	2.5											5530	5540		
60	65	75	2.5												6030	6040	

配合軸公差 f7，孔座公差 H7. Installed with f7 journals and H7 housing bore



PFW THRUST WASHERS
STANDARD

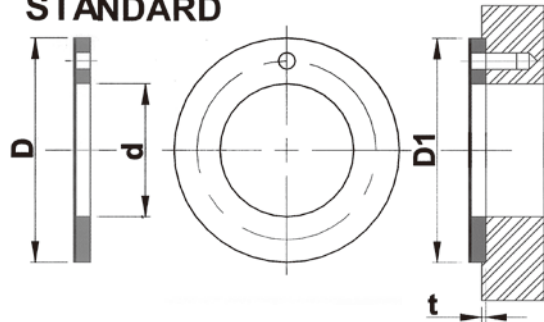

產品標示法: PFW-d(PFW-內徑)

規格 esignation	墊片尺寸 Size of washer				安裝尺寸 Size of installation		
	Ød	ØD	T	M	h	t	D1
	+0.25 0	0 -0.25	0 -0.05	+0.12 -0.12	+0.4 +0.1	+0.2 -0.2	+0.12 0
PFW08	8	16	1.5	12	1	1	16
PFW10	10	20	1.5	15	1.5	1	20
PFW12	12	24	1.5	18	1.5	1	24
PFW14	14	26	1.5	20	2	1	26
PFW16	16	30	1.5	23	2	1	30
PFW18	18	32	1.5	25	2	1	32
PFW20	20	36	1.5	28	3	1	36
PFW22	22	38	1.5	30	3	1	38
PFW24	24	42	1.5	33	3	1	42
PFW26	26	44	1.5	35	3	1	44
PFW28	28	48	1.5	38	4	1	48
PFW32	32	54	1.5	43	4	1	54
PFW38	38	62	1.5	50	4	1	62
PFW42	42	66	1.5	54	4	1	66
PFW48	48	74	2	61	4	1.5	74
PFW52	52	78	2	65	4	1.5	78
PFW62	62	90	2	76	4	1.5	90

PFP 自潤滑板標準尺寸

PFP DRYMET PLATE STANDARD

規格 TYPE	長度 Length±1	寬度 Width±1	厚度 Thickness-0.04
PFP-10125	500	125	1.0
PFP-15125	500	125	1.5
PFP-20140	500	140	2.0
PFP-25140	500	140	2.5